

序号 MARK	设变内容 MODIFICATION	日期 DATE	修改 DRAW	核准 APPROVE

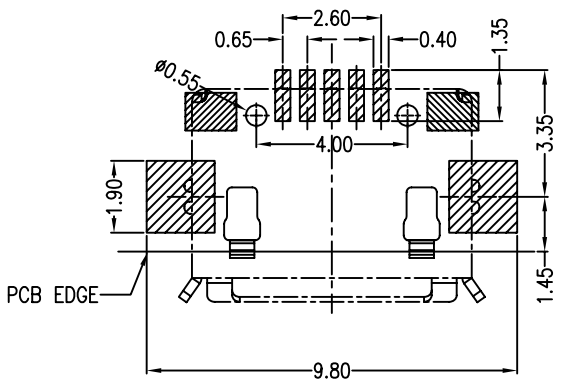
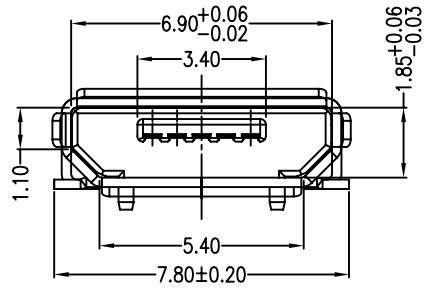
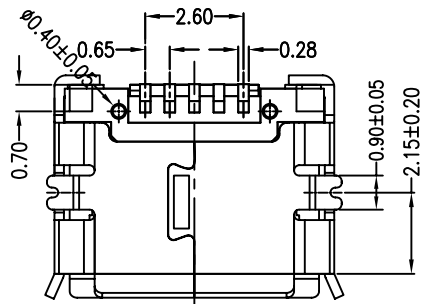
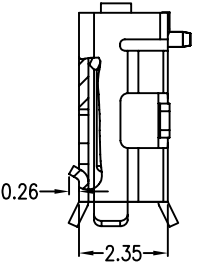
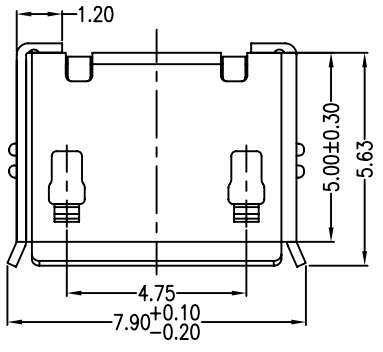
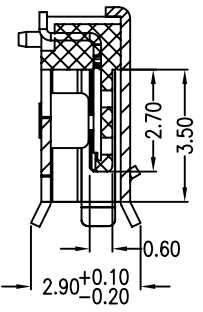
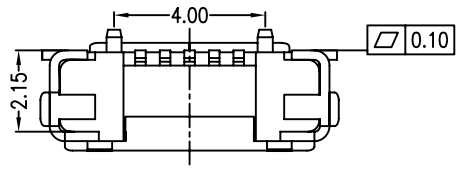

- Note:
1. Material:
 - 1.1 Housing: High temperature thermoplastic with g.f,UL94v-0
 - 1.2 Contact: copper alloy,t=0.20mm
 - 1.3 Shell: copper alloy,t=0.25mm
 2. Specification:
 - 2.1 Current rating: 1 A Max.
 - 2.2 Dielectric withstanding voltage: 100 V(ac) for 1 min.
 - 2.3 Contact resistance: 50 mW Max.
 - 2.4 Insulation resistance: 100 MW Min.
 - 2.5 Total mating force: 3.57 Kgf Max.
 - 2.6 Total unmating force: 1.0 Kgf Min.0.81~2.05 Kgf Min.after 10000 insertion/extraction cycles
 - 2.7 Temperature range: -30°C~80°C

一般公差		比例 N/A	绘图	日期	料号	版次 1.0 REV.
XX ±	XXX ±	SCALE	DRAWIN	2012.06.06	PAPT NO.:	
.X ± 0.25	.XXX ±	单位 MM	审核	日期	名称	Micro usb 5s 全贴有焊脚有柱
.XX ± 0.15	X.° ± 2°	UNIT	CHECKED	日期	TITLE	
.XXX ± 0.05	.X° ± 0.5°	尺寸 A4	核准	日期		页次 1/1 PAGE
		SIZE	APPROVE	DATE		